

# FAIRBANKS®

## AEGIS® DRUM SCALES



Fairbanks' new Aegis Drum Scale is not just for weighing drums; its live side rails make it ideal for weighing a number of other industrial containers such as pallets, totes and bulk products.

Fairbanks' holistic approach to floor scale design is a result of more than 175 years of proven design experience, along with today's latest weighing technology. The Aegis Drum Scale will change your expectation of how a drum scale should perform.

### FEATURES

- Multiple sizes and capacities.
- Low 1.5" platform profile for easy load introduction.
- Live 3" high side rails for pallet weighing.
- Built-in lifting eyes for easy portability.
- Bubble level for instant visual accuracy confirmation.
- Smooth deck plate for easy clean-up.
- Platform utilizes the latest load cell technology:
  - Patented load cell that never requires maintenance.
  - IP69K-rated load cells (standard on stainless model, optional on mild steel models) eliminates washdown and spillage concerns.
  - Unique load introduction offers the highest degree of accuracy and repeatability in the market.
- Adjustable leveling feet accommodate uneven floor surfaces.

### APPLICATIONS

The Aegis Drum Scale is designed and engineered with a variety of weighing applications in mind, including:

- Manufacturing
- Food & beverage
- Chemical
- Textile
- Scrap or recycling
- Pharmaceutical

### SPECIFICATIONS

#### Drum Scale:

Capacities (lbs) . . . . .	500, 1000, 2000, 2500
Platform	
Sizes . . . . .	30" x 30" and 38" x 38"
Height . . . . .	1.5" (3" live side rail)
Finish . . . . .	Smooth plate
Endloading . . . . .	100% of capacity all models except 2500 lb model, which is rated at 80%
Cable length . . . . .	Platform to instrument = 30 feet
Cable protection . . . . .	PVC jacketed
Construction . . . . .	Mild steel with black enamel finish; Type 304 PH stainless steel, brushed
Approvals . . . . .	NTEP CC# 08-044; MC #AM-5674

#### Load cell:

Capacity . . . . .	500 and 1000 lbs
Excitation voltage . . . . .	5 to 15 VDC
Construction . . . . .	17-4 PH stainless steel
Sealing . . . . .	IP67 (mild steel scale) and IP69K (ss scale)
Approvals . . . . .	FM; NTEP CC# 06-065 (mild steel scale); NTEP CC# 04-102 (stainless steel scale)

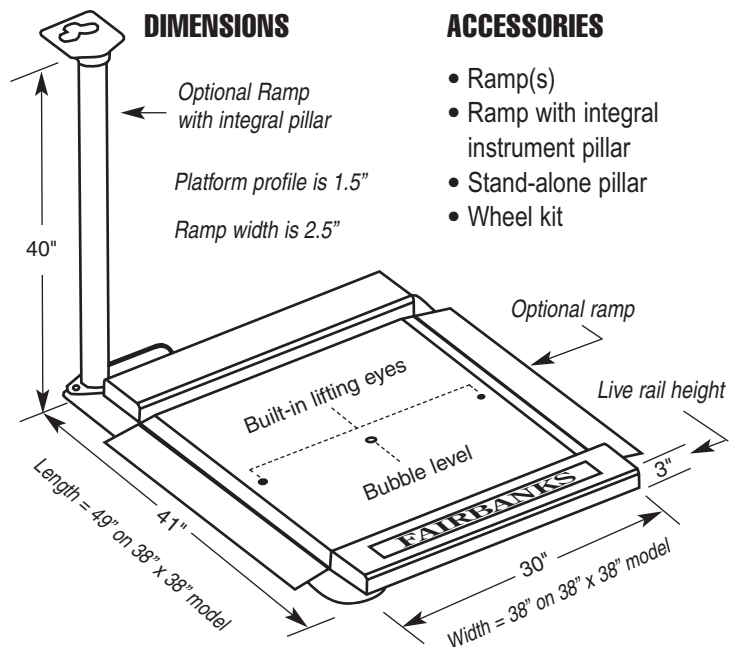

### QuickFacts™

Models and specifications subject to change without notice. Printed in the USA. © Fairbanks Scales Inc.

Call toll-free for the Fairbanks representative nearest you:

**(800) 451-4107**

Internet Address: <http://www.Fairbanks.com>